

FINAL JEE-MAIN EXAMINATION – JANUARY, 2024

(Held On Monday 29th January, 2024)

TIME : 3 : 00 PM to 6 : 00 PM

PHYSICS

TEST PAPER WITH SOLUTION

SECTION-A

31. Two sources of light emit with a power of 200 W. The ratio of number of photons of visible light emitted by each source having wavelengths 300 nm and 500 nm respectively, will be :

- (1) 1 : 5 (2) 1 : 3
(3) 5 : 3 (4) 3 : 5

Ans. (4)

Sol. $n_1 \times \frac{hc}{\lambda_1} = 200$

$n_2 \times \frac{hc}{\lambda_2} = 200$

$\frac{n_1}{n_2} = \frac{\lambda_1}{\lambda_2} = \frac{300}{500}$

$\frac{n_1}{n_2} = \frac{3}{5}$

32. The truth table for this given circuit is :

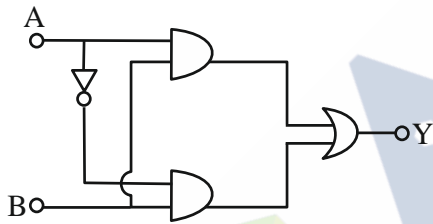

(1)

A	B	Y
0	0	1
0	1	1
1	0	1
1	1	0

(2)

A	B	Y
0	0	0
0	1	1
1	0	0
1	1	1

(3)

A	B	Y
0	0	0
0	1	0
1	0	0
1	1	1

(4)

A	B	Y
0	0	1
0	1	0
1	0	1
1	1	0

Ans. (2)

Sol.

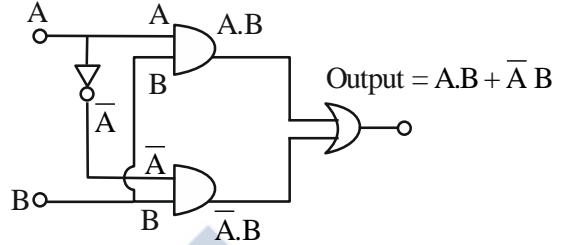

$Y = A.B + \bar{A}.B$
 $= (A + \bar{A}).B$

$Y = 1.B$
 $Y = B$

33. A physical quantity Q is found to depend on quantities a, b, c by the relation $Q = \frac{a^4 b^3}{c^2}$. The percentage error in a, b and c are 3%, 4% and 5% respectively. Then, the percentage error in Q is :

- (1) 66% (2) 43%
(3) 34% (4) 14%

Ans. (3)

Sol. $Q = \frac{a^4 b^3}{c^2}$

$\frac{\Delta Q}{Q} = 4 \frac{\Delta a}{a} + 3 \frac{\Delta b}{b} + 2 \frac{\Delta c}{c}$

$\frac{\Delta Q}{Q} \times 100 = 4 \left(\frac{\Delta a}{a} \times 100 \right) + 3 \left(\frac{\Delta b}{b} \times 100 \right) + 2 \left(\frac{\Delta c}{c} \times 100 \right)$

% error in Q = $4 \times 3\% + 3 \times 4\% + 2 \times 5\%$
 $= 12\% + 12\% + 10\%$
 $= 34\%$

34. In an a.c. circuit, voltage and current are given by :
 $V = 100 \sin (100 t)$ V and

$I = 100 \sin (100 t + \frac{\pi}{3})$ mA respectively.

The average power dissipated in one cycle is :

- (1) 5 W (2) 10 W
(3) 2.5 W (4) 25 W

Ans. (3)



Sol. $P_{avg} = V_{rms} I_{rms} \cos(\Delta\phi)$

$$= \frac{100}{\sqrt{2}} \times \frac{100 \times 10^{-3}}{\sqrt{2}} \times \cos\left(\frac{\pi}{3}\right)$$

$$= \frac{10^4}{2} \times \frac{1}{2} \times 10^{-3}$$

$$= \frac{10}{4} = 2.5 \text{ W}$$

35. The temperature of a gas having 2.0×10^{25} molecules per cubic meter at 1.38 atm (Given, $k = 1.38 \times 10^{-23} \text{ JK}^{-1}$) is :

- (1) 500 K (2) 200 K
(3) 100 K (4) 300 K

Ans. (1)

Sol. $PV = nRT$

$$PV = \frac{N}{N_A} RT$$

$N =$ Total no. of molecules

$$P = \frac{N}{V} kT$$

$$1.38 \times 1.01 \times 10^5 = 2 \times 10^{25} \times 1.38 \times 10^{-23} \times T$$

$$1.01 \times 10^5 = 2 \times 10^2 \times T$$

$$T = \frac{1.01 \times 10^3}{2} \approx 500 \text{ K}$$

36. A stone of mass 900g is tied to a string and moved in a vertical circle of radius 1m making 10 rpm. The tension in the string, when the stone is at the lowest point is (if $\pi^2 = 9.8$ and $g = 9.8 \text{ m/s}^2$)

- (1) 97 N (2) 9.8 N
(3) 8.82 N (4) 17.8 N

Ans. (2)

Sol. Given that

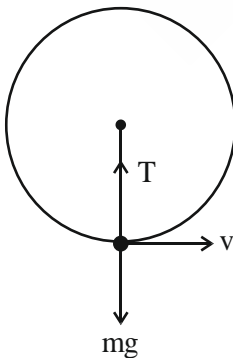

$$m = 900 \text{ gm} = \frac{900}{1000} \text{ kg} = \frac{9}{10} \text{ kg}$$

$$r = 1 \text{ m}$$

$$\omega = \frac{2\pi N}{60} = \frac{2\pi(10)}{60} = \frac{\pi}{3} \text{ rad/sec}$$

$$T - mg = m\omega^2 r$$

$$T = mg + m\omega^2 r$$

$$= \frac{9}{10} \times 9.8 + \frac{9}{10} \times 1 \times \left(\frac{\pi}{3}\right)^2$$

$$= 8.82 + \frac{9}{10} \times \frac{\pi^2}{9}$$

$$= 8.82 + 0.98$$

$$= 9.80 \text{ N}$$

37. The bob of a pendulum was released from a horizontal position. The length of the pendulum is 10m. If it dissipates 10% of its initial energy against air resistance, the speed with which the bob arrives at the lowest point is : [Use, $g : 10 \text{ ms}^{-2}$]

- (1) $6\sqrt{5} \text{ ms}^{-1}$ (2) $5\sqrt{6} \text{ ms}^{-1}$
(3) $5\sqrt{5} \text{ ms}^{-1}$ (4) $2\sqrt{5} \text{ ms}^{-1}$

Ans. (1)

Sol. $\ell = 10 \text{ m}$,

$$\text{Initial energy} = mg\ell$$

$$\text{So, } \frac{9}{10} mg\ell = \frac{1}{2} mv^2$$

$$\Rightarrow \frac{9}{10} \times 10 \times 10 = \frac{1}{2} v^2$$

$$v^2 = 180$$

$$v = \sqrt{180} = 6\sqrt{5} \text{ m/s}$$

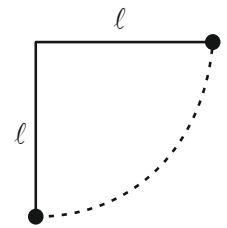

38. If the distance between object and its two times magnified virtual image produced by a curved mirror is 15 cm, the focal length of the mirror must be :

- (1) 15 cm (2) -12 cm
(3) -10 cm (4) 10/3 cm

Ans. (3)



Sol.

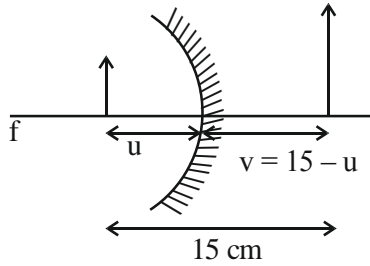

$$m = 2 = \frac{-v}{u}$$

$$2 = \frac{-(15 - u)}{-u}$$

$$2u = 15 - u$$

$$3u = 15 \Rightarrow u = 5 \text{ cm}$$

$$v = 15 - u = 15 - 5 = 10 \text{ cm}$$

$$\frac{1}{f} = \frac{1}{v} + \frac{1}{u}$$

$$= \frac{1}{10} + \frac{1}{(-5)} = \frac{1-2}{10} = \frac{-1}{10}$$

$$f = -10 \text{ cm}$$

39. Two particles X and Y having equal charges are being accelerated through the same potential difference. Thereafter they enter normally in a region of uniform magnetic field and describes circular paths of radii R_1 and R_2 respectively. The mass ratio of X and Y is :

- (1) $\left(\frac{R_2}{R_1}\right)^2$ (2) $\left(\frac{R_1}{R_2}\right)^2$
 (3) $\left(\frac{R_1}{R_2}\right)$ (4) $\left(\frac{R_2}{R_1}\right)$

Ans. (2)

Sol. $R = \frac{mv}{qB} = \frac{p}{qB} = \frac{\sqrt{2m(\text{KE})}}{qB} = \frac{\sqrt{2mqV}}{qB}$

$$R \propto \sqrt{m}$$

$$m \propto R^2$$

$$\frac{m_1}{m_2} = \left(\frac{R_1}{R_2}\right)^2$$

40. In Young's double slit experiment, light from two identical sources are superimposing on a screen. The path difference between the two lights reaching at a point on the screen is $\frac{7\lambda}{4}$. The ratio of intensity of fringe at this point with respect to the maximum intensity of the fringe is :

(1) 1/2 (2) 3/4 (3) 1/3 (4) 1/4

Ans. (1)

Sol. $\Delta x = \frac{7\lambda}{4}$

$$\phi = \frac{2\pi}{\lambda} \Delta x = \frac{2\pi}{\lambda} \times \frac{7\lambda}{4} = \frac{7\pi}{2}$$

$$I = I_{\max} \cos^2\left(\frac{\phi}{2}\right)$$

$$\frac{I}{I_{\max}} = \cos^2\left(\frac{\phi}{2}\right) = \cos^2\left(\frac{7\pi}{2 \times 2}\right) = \cos^2\left(\frac{7\pi}{4}\right)$$

$$= \cos^2\left(2\pi - \frac{\pi}{4}\right)$$

$$= \cos^2 \frac{\pi}{4}$$

$$= \frac{1}{2}$$

41. A small liquid drop of radius R is divided into 27 identical liquid drops. If the surface tension is T, then the work done in the process will be :

- (1) $8\pi R^2 T$ (2) $3\pi R^2 T$
 (3) $\frac{1}{8}\pi R^2 T$ (4) $4\pi R^2 T$

Ans. (1)

Sol. Volume constant

$$\frac{4}{3}\pi R^3 = 27 \times \frac{4}{3}\pi r^3$$

$$R^3 = 27r^3$$

$$R = 3r$$

$$r = \frac{R}{3}$$

$$r^2 = \frac{R^2}{9}$$

Work done = $T \cdot \Delta A$

$$= 27 T(4\pi r^2) - T 4\pi R^2$$

$$= 27 T 4\pi \frac{R^2}{9} - 4\pi R^2 T$$

$$= 8\pi R^2 T$$



42. A bob of mass 'm' is suspended by a light string of length 'L'. It is imparted a minimum horizontal velocity at the lowest point A such that it just completes half circle reaching the top most position B. The ratio of kinetic energies $\frac{(K.E.)_A}{(K.E.)_B}$ is :

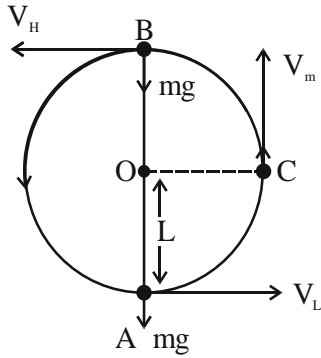

- (1) 3 : 2 (2) 5 : 1
(3) 2 : 5 (4) 1 : 5

Ans. (2)

Sol. Apply energy conservation between A & B

$$\frac{1}{2}mV_L^2 = \frac{1}{2}mV_H^2 + mg(2L)$$

$$\therefore V_L = \sqrt{5gL}$$

$$\text{So, } V_H = \sqrt{gL}$$

$$\frac{(K.E.)_A}{(K.E.)_B} = \frac{\frac{1}{2}m(\sqrt{5gL})^2}{\frac{1}{2}m(\sqrt{gL})^2} = \frac{5}{1}$$

43. A wire of length L and radius r is clamped at one end. If its other end is pulled by a force F, its length increases by l. If the radius of the wire and the applied force both are reduced to half of their original values keeping original length constant, the increase in length will become.

- (1) 3 times (2) 3/2 times
(3) 4 times (4) 2 times

Ans. (4)

Sol. $Y = \frac{\text{stress}}{\text{strain}}$

$$Y = \frac{\frac{F}{\pi r^2}}{\frac{\Delta l}{L}}$$

$$F = Y\pi r^2 \times \frac{\Delta l}{L} \quad \dots(i)$$

$$Y = \frac{F/2}{\frac{\Delta l}{L}}$$

$$F = Y \frac{\Delta l}{L} \times 2 \times \frac{\pi r^2}{4}$$

From (i)

$$Y\pi r^2 \frac{\Delta l}{L} = Y \frac{\Delta l}{L} \frac{\pi r^2}{2}$$

$$\Delta l = 2l$$

44. A planet takes 200 days to complete one revolution around the Sun. If the distance of the planet from Sun is reduced to one fourth of the original distance, how many days will it take to complete one revolution ?

- (1) 25 (2) 50
(3) 100 (4) 20

Ans. (1)

Sol. $T^2 \propto r^3$

$$\frac{T_1^2}{r_1^3} = \frac{T_2^2}{r_2^3}$$

$$\frac{(200)^2}{r^3} = \frac{T_2^2}{\left(\frac{r}{4}\right)^3}$$

$$\frac{200 \times 200}{4 \times 4 \times 4} = T_2^2$$

$$T_2 = \frac{200}{4 \times 2}$$

$$T_2 = 25 \text{ days}$$



45. A plane electromagnetic wave of frequency 35 MHz travels in free space along the X-direction. At a particular point (in space and time) $\vec{E} = 9.6\hat{j}\text{V/m}$. The value of magnetic field at this point is :

- (1) $3.2 \times 10^{-8} \hat{k}\text{T}$ (2) $3.2 \times 10^{-8} \hat{i}\text{T}$
 (3) $9.6\hat{j}\text{T}$ (4) $9.6 \times 10^{-8} \hat{k}\text{T}$

Ans. (1)

Sol. $\frac{E}{B} = C$

$\frac{E}{B} = 3 \times 10^8$

$B = \frac{E}{3 \times 10^8} = \frac{9.6}{3 \times 10^8}$

$B = 3.2 \times 10^{-8} \text{ T}$

$\hat{B} = \hat{v} \times \hat{E}$

$= \hat{i} \times \hat{j} = \hat{k}$

So,

$\vec{B} = 3.2 \times 10^{-8} \hat{k} \text{ T}$

46. In the given circuit, the current in resistance R_3 is :

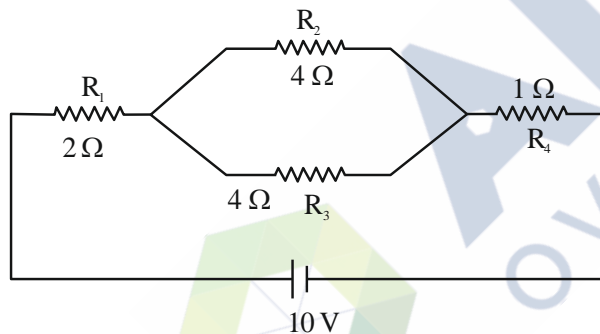

- (1) 1 A (2) 1.5 A
 (3) 2 A (4) 2.5 A

Ans. (1)

Sol.

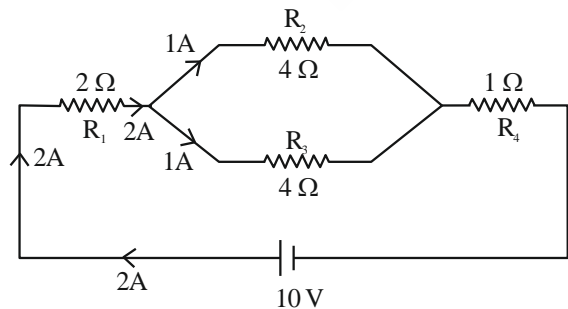

$R_{eq} = 2\Omega + 2\Omega + 1\Omega = 5\Omega$

$i = \frac{V}{R_{eq}} = \frac{10}{5} = 2\text{A}$

Current in resistance $R_3 = 2 \times \left(\frac{4}{4+4}\right)$
 $= 2 \times \frac{4}{8}$
 $= 1\text{A}$

47. A particle is moving in a straight line. The variation of position 'x' as a function of time 't' is given as $x = (t^3 - 6t^2 + 20t + 15)$ m. The velocity of the body when its acceleration becomes zero is :

- (1) 4 m/s (2) 8 m/s
 (3) 10 m/s (4) 6 m/s

Ans. (2)

Sol. $x = t^3 - 6t^2 + 20t + 15$

$\frac{dx}{dt} = v = 3t^2 - 12t + 20$

$\frac{dv}{dt} = a = 6t - 12$

When $a = 0$

$6t - 12 = 0; t = 2 \text{ sec}$

At $t = 2 \text{ sec}$

$v = 3(2)^2 - 12(2) + 20$

$v = 8 \text{ m/s}$

48. N moles of a polyatomic gas ($f = 6$) must be mixed with two moles of a monoatomic gas so that the mixture behaves as a diatomic gas. The value of N is :

- (1) 6 (2) 3 (3) 4 (4) 2

Ans. (3)

Sol. $f_{eq} = \frac{n_1 f_1 + n_2 f_2}{n_1 + n_2}$

For diatomic gas $f_{eq} = 5$

$5 = \frac{(N)(6) + (2)(3)}{N + 2}$

$5N + 10 = 6N + 6$

$N = 4$



49. Given below are two statements :

Statement I : Most of the mass of the atom and all its positive charge are concentrated in a tiny nucleus and the electrons revolve around it, is Rutherford's model.

Statement II : An atom is a spherical cloud of positive charges with electrons embedded in it, is a special case of Rutherford's model.

In the light of the above statements, choose the most appropriate from the options given below.

- (1) Both statement I and statement II are false
- (2) Statement I is false but statement II is true
- (3) Statement I is true but statement II is false
- (4) Both statement I and statement II are true

Ans. (3)

Sol. According to Rutherford atomic model, most of mass of atom and all its positive charge is concentrated in tiny nucleus & electron revolve around it.

According to Thomson atomic model, atom is spherical cloud of positive charge with electron embedded in it.

Hence,

Statement I is true but statement II false.

50. An electric field is given by $(6\hat{i} + 5\hat{j} + 3\hat{k})$ N/C.

The electric flux through a surface area $30\hat{i}$ m² lying in YZ-plane (in SI unit) is :

- (1) 90
- (2) 150
- (3) 180
- (4) 60

Ans. (3)

Sol. $\vec{E} = 6\hat{i} + 5\hat{j} + 3\hat{k}$

$$\vec{A} = 30\hat{i}$$

$$\phi = \vec{E} \cdot \vec{A}$$

$$\phi = (6\hat{i} + 5\hat{j} + 3\hat{k}) \cdot (30\hat{i})$$

$$\phi = 6 \times 30 = 180$$

SECTION-B

51. Two metallic wires P and Q have same volume and are made up of same material. If their area of cross sections are in the ratio 4 : 1 and force F_1 is applied to P, an extension of Δl is produced. The force which is required to produce same extension in Q is F_2 .

The value of $\frac{F_1}{F_2}$ is _____.

Ans. (16)

Sol. $Y = \frac{\text{Stress}}{\text{Strain}} = \frac{F/A}{\Delta l/l} = \frac{Fl}{A\Delta l}$

$$\Delta l = \frac{Fl}{AY}$$

$$V = A\ell \Rightarrow \ell = \frac{V}{A}$$

$$\Delta l = \frac{FV}{A^2Y}$$

Y & V is same for both the wires

$$\Delta l \propto \frac{F}{A^2}$$

$$\frac{\Delta l_1}{\Delta l_2} = \frac{F_1}{A_1^2} \times \frac{A_2^2}{F_2}$$

$$\Delta l_1 = \Delta l_2$$

$$F_1 A_2^2 = F_2 A_1^2$$

$$\frac{F_1}{F_2} = \frac{A_1^2}{A_2^2} = \left(\frac{4}{1}\right)^2 = 16$$

52. A horizontal straight wire 5 m long extending from east to west falling freely at right angle to horizontal component of earth's magnetic field 0.60×10^{-4} Wb m⁻². The instantaneous value of emf induced in the wire when its velocity is 10 ms^{-1} is _____ $\times 10^{-3}$ V.

Ans. (3)

Sol. $B_H = 0.60 \times 10^{-4}$ Wb/m²

Induced emf $e = B_H v \ell$

$$= 0.60 \times 10^{-4} \times 10 \times 5$$

$$= 3 \times 10^{-3} \text{ V}$$

53. Hydrogen atom is bombarded with electrons accelerated through a potential different of V, which causes excitation of hydrogen atoms. If the experiment is being formed at $T = 0$ K. The minimum potential difference needed to observe any Balmer series lines in the emission spectra will be $\frac{\alpha}{10}$ V, where $\alpha =$ _____.

Ans. (121)



Sol. For minimum potential difference electron has to make transition from $n = 3$ to $n = 2$ state but first electron has to reach to $n = 3$ state from ground state. So, energy of bombarding electron should be equal to energy difference of $n = 3$ and $n = 1$ state.

$$\Delta E = 13.6 \left[1 - \frac{1}{3^2} \right] e = eV$$

$$\frac{13.6 \times 8}{9} = V$$

$$V = 12.09 \text{ V} \approx 12.1 \text{ V}$$

$$\text{So, } \alpha = 121$$

54. A charge of $4.0 \mu\text{C}$ is moving with a velocity of $4.0 \times 10^6 \text{ ms}^{-1}$ along the positive y-axis under a magnetic field \vec{B} of strength $(2\hat{k})$ T. The force acting on the charge is $x\hat{i}$ N. The value of x is ___.

Ans. (32)

Sol. $q = 4 \mu\text{C}$, $\vec{v} = 4 \times 10^6 \hat{j} \text{ m/s}$

$$\vec{B} = 2\hat{k}\text{T}$$

$$\vec{F} = q(\vec{v} \times \vec{B})$$

$$= 4 \times 10^{-6} (4 \times 10^6 \hat{j} \times 2\hat{k})$$

$$= 4 \times 10^{-6} \times 8 \times 10^6 \hat{i}$$

$$\vec{F} = 32\hat{i} \text{ N}$$

$$x = 32$$

55. A simple harmonic oscillator has an amplitude A and time period 6π second. Assuming the oscillation starts from its mean position, the time required by it to travel from $x = A$ to $x = \frac{\sqrt{3}}{2}A$

will be $\frac{\pi}{x}$ s, where $x =$ _____.

Ans. (2)

Sol.

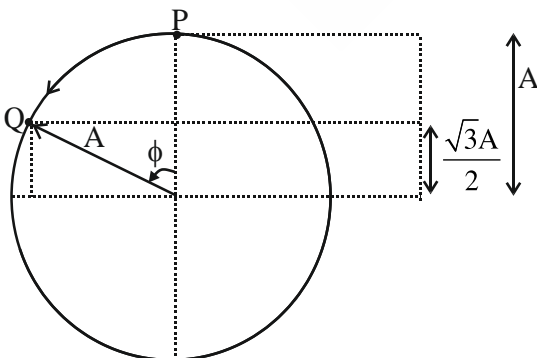

From phasor diagram particle has to move from P to Q in a circle of radius equal to amplitude of SHM.

$$\cos \phi = \frac{\frac{\sqrt{3}A}{2}}{A} = \frac{\sqrt{3}}{2}$$

$$\phi = \frac{\pi}{6}$$

$$\text{Now, } \frac{\pi}{6} = \omega t$$

$$\frac{\pi}{6} = \frac{2\pi}{T} t$$

$$\frac{\pi}{6} = \frac{2\pi}{6\pi} t$$

$$t = \frac{\pi}{2}$$

$$\text{So, } x = 2$$

56. In the given figure, the charge stored in $6\mu\text{F}$ capacitor, when points A and B are joined by a connecting wire is _____ μC .

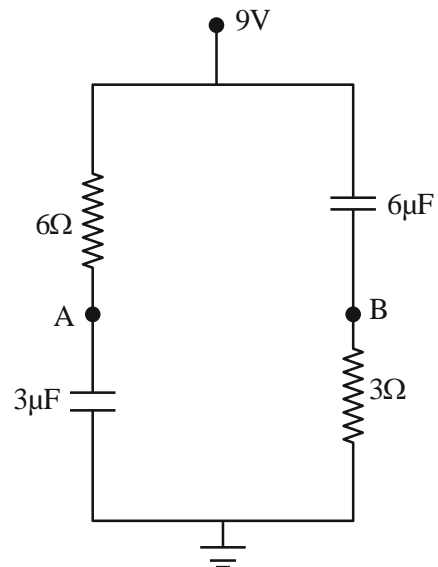

Ans. (36)



Sol. At steady state, capacitor behaves as an open circuit and current flows in circuit as shown in the diagram.

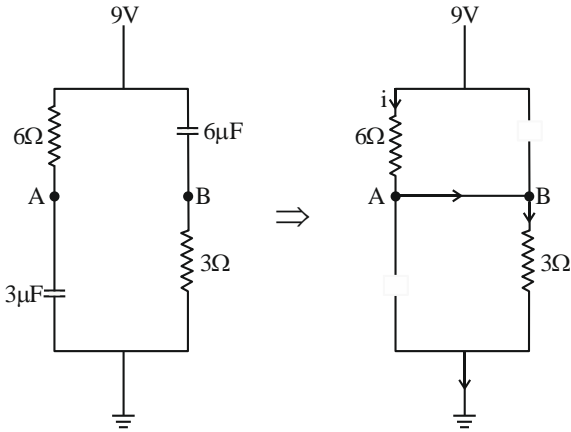

$$R_{eq} = 9 \Omega$$

$$i = \frac{9 \text{ V}}{9 \Omega} = 1 \text{ A}$$

$$\Delta V_{6\Omega} = 1 \times 6 = 6 \text{ V}$$

$$V_A = 3 \text{ V}$$

So, potential difference across $6\mu\text{F}$ is 6 V.

Hence $Q = C\Delta V$

$$= 6 \times 6 \times 10^{-6} \text{ C}$$

$$= 36 \mu\text{C}$$

57. In a single slit diffraction pattern, a light of wavelength 6000 \AA is used. The distance between the first and third minima in the diffraction pattern is found to be 3 mm when the screen is placed 50 cm away from slits. The width of the slit is $\text{_____} \times 10^{-4} \text{ m}$.

Ans. (2)

Sol. For n^{th} minima

$$b \sin \theta = n\lambda$$

(λ is small so $\sin \theta$ is small, hence $\sin \theta \approx \tan \theta$)

$$b \tan \theta = n\lambda$$

$$b \frac{y}{D} = n\lambda$$

$$\Rightarrow y_n = \frac{n\lambda D}{b} \text{ (Position of } n^{\text{th}} \text{ minima)}$$

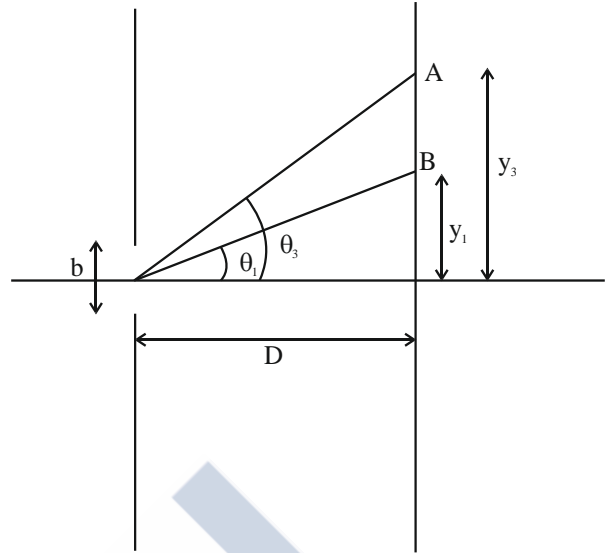

$B \rightarrow 1^{\text{st}}$ minima, $A \rightarrow 3^{\text{rd}}$ minima

$$y_3 = \frac{3\lambda D}{b}, \quad y_1 = \frac{\lambda D}{b}$$

$$\Delta y = y_3 - y_1 = \frac{2\lambda D}{b}$$

$$3 \times 10^{-3} = \frac{2 \times 6000 \times 10^{-10} \times 0.5}{b}$$

$$b = \frac{2 \times 6000 \times 10^{-10} \times 0.5}{3 \times 10^{-3}}$$

$$b = 2 \times 10^{-4} \text{ m}$$

$$x = 2$$

58. In the given circuit, the current flowing through the resistance 20Ω is 0.3 A, while the ammeter reads 0.9 A. The value of R_1 is $\text{_____} \Omega$.

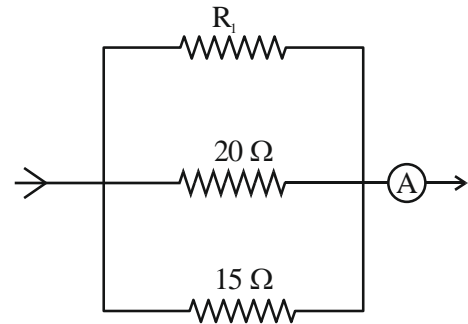

Ans. (30)

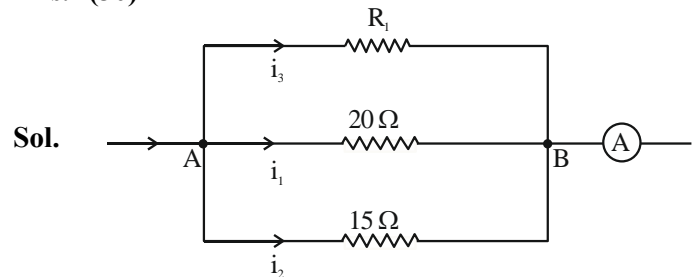

Sol.

Given, $i_1 = 0.3 \text{ A}$, $i_1 + i_2 + i_3 = 0.9 \text{ A}$

So, $V_{AB} = i_1 \times 20\Omega = 20 \times 0.3 \text{ V} = 6 \text{ V}$



$$i_2 = \frac{6V}{15\Omega} = \frac{2}{5} \text{ A}$$

$$i_1 + i_2 + i_3 = \frac{9}{10} \text{ A}$$

$$\frac{3}{10} + \frac{2}{5} + i_3 = \frac{9}{10}$$

$$\frac{7}{10} + i_3 = \frac{9}{10}$$

$$i_3 = 0.2 \text{ A}$$

$$\text{So, } i_3 \times R_1 = 6 \text{ V}$$

$$(0.2)R_1 = 6$$

$$R_1 = \frac{6}{0.2} = 30 \Omega$$

59. A particle is moving in a circle of radius 50 cm in such a way that at any instant the normal and tangential components of its acceleration are equal. If its speed at $t = 0$ is 4 m/s, the time taken to complete the first revolution will be $\frac{1}{\alpha} [1 - e^{-2\pi}]$ s, where $\alpha = \underline{\hspace{2cm}}$.

Ans. (8)

Sol. $|\vec{a}_c| = |\vec{a}_t|$

$$\frac{v^2}{r} = \frac{dv}{dt}$$

$$\Rightarrow \int_4^v \frac{dv}{v^2} = \int_0^t \frac{dt}{r}$$

$$\Rightarrow \left[\frac{-1}{v} \right]_4^v = \frac{t}{r}$$

$$\Rightarrow \frac{-1}{v} + \frac{1}{4} = \frac{t}{r}$$

$$\Rightarrow v = \frac{4}{1-8t} = \frac{ds}{dt}$$

$$4 \int_0^t \frac{dt}{1-8t} = \int_0^s ds$$

$$(r = 0.5 \text{ m})$$

$$s = 2\pi r = \pi$$

$$4 \times \frac{[\ln(1-8t)]_0^t}{-8} = \pi$$

$$\ln(1-8t) = -2\pi$$

$$1-8t = e^{-2\pi}$$

$$t = (1 - e^{-2\pi}) \frac{1}{8} \text{ s}$$

$$\text{So, } \alpha = 8$$

60. A body of mass 5 kg moving with a uniform speed $3\sqrt{2} \text{ ms}^{-1}$ in X-Y plane along the line $y = x + 4$. The angular momentum of the particle about the origin will be $\underline{\hspace{2cm}}$ $\text{kg m}^2\text{s}^{-1}$.

Ans. (60)

Sol. $y - x - 4 = 0$

d_1 is perpendicular distance of given line from origin.

$$d_1 = \left| \frac{-4}{\sqrt{1^2 + 1^2}} \right| \Rightarrow 2\sqrt{2} \text{ m}$$

$$\text{So, } |\vec{L}| = mvd_1 = 5 \times 3\sqrt{2} \times 2\sqrt{2} \text{ kg m}^2/\text{s} \\ = 60 \text{ kg m}^2/\text{s}$$

