

35. Electromagnetic waves travel in a medium with speed of $1.5 \times 10^8 \text{ ms}^{-1}$. The relative permeability of the medium is 2.0. The relative permittivity will be :

- (1) 5 (2) 1
(3) 4 (4) 2

Ans. (4)

Sol.
$$\frac{\epsilon_m \times \mu_m}{\epsilon_0 \times \mu_0} = \frac{1}{v^2}$$

$$\epsilon_r \times \mu_r = \frac{c^2}{v^2}$$

$$\epsilon_r \times 2 = \frac{(3 \times 10^8)^2}{(1.5 \times 10^8)^2}$$

$$\epsilon_r \times 2 = 4$$

$$\epsilon_r = 2$$

36. Which of the following phenomena does not explain by wave nature of light.

- (A) reflection (B) diffraction
(C) photoelectric effect (D) interference
(E) polarization

Choose the **most appropriate** answer from the options given below :

- (1) E only (2) C only
(3) B, D only (4) A, C only

Ans. (2)

Sol. (Theory)

Photoelectric effect prove particle nature of light.

37. While measuring diameter of wire using screw gauge the following readings were noted. Main scale reading is 1 mm and circular scale reading is equal to 42 divisions. Pitch of screw gauge is 1 mm and it has 100 divisions on circular scale. The

diameter of the wire is $\frac{x}{50}$ mm . The value of x is :

- (1) 142 (2) 71
(3) 42 (4) 21

Ans. (2)

Sol. MSR = 1mm, CSR = 42, pitch = 1 mm

$$LC = \frac{\text{pitch}}{\text{No. of CSD}} = \left(\frac{1}{100} \right) = 0.01 \text{mm}$$

Diameter = MSR + LC × CSD

Diameter = 1 + (0.01) × 42 mm

Diameter = 1.42 mm = $\frac{x}{50}$

∴ x = 71

38. σ is the uniform surface charge density of a thin spherical shell of radius R. The electric field at any point on the surface of the spherical shell is :

- (1) $\sigma/\epsilon_0 R$ (2) $\sigma/2\epsilon_0$
(3) σ/ϵ_0 (4) $\sigma/4\epsilon_0$

Ans. (3)

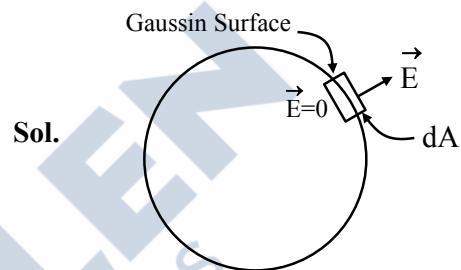

Sol.

By Gauss law
$$\int \vec{E} \cdot d\vec{A} = \frac{q_{in}}{\epsilon_0}$$

$$EdA = \frac{\sigma \times dA}{\epsilon_0}$$

$$E = \frac{\sigma}{\epsilon_0}$$

39. The value of unknown resistance (x) for which the potential difference between B and D will be zero in the arrangement shown, is :

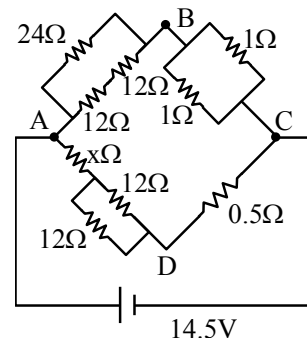

- (1) 3 Ω (2) 9 Ω
(3) 6 Ω (4) 42 Ω

Ans. (3)

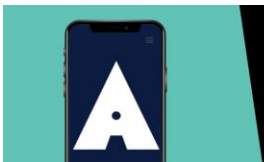

Download the new **ALLEN** app
& enroll for **Online Programs**

CLICK HERE TO
DOWNLOAD

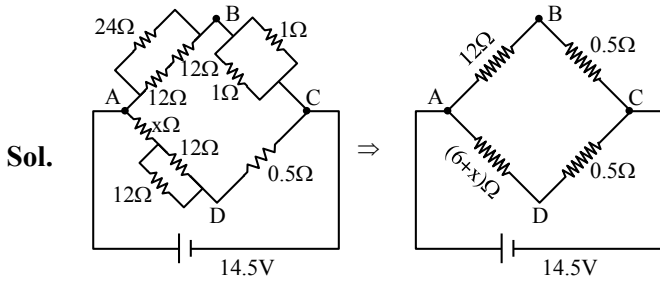

In case of balanced Wheatstone Bridge

$$\frac{V_{AB}}{V_{AD}} = \frac{V_{BC}}{V_{CD}} \Rightarrow \frac{12}{6+x} = \frac{0.5}{0.5}$$

$$x = 6 \Omega$$

40. The specific heat at constant pressure of a real gas obeying $PV^2 = RT$ equation is :

- (1) $C_v + R$ (2) $\frac{R}{3} + C_v$
 (3) R (4) $C_v + \frac{R}{2V}$

Ans. (4)

Sol. $dQ = du + dW$

$$CdT = C_v dT + PdV \quad \dots(1)$$

$$\therefore PV^2 = RT$$

$$P = \text{constant}$$

$$P(2VdV) = RdT$$

$$PdV = \frac{RdT}{2V}$$

Put in equation (1)

$$C = C_v + \frac{R}{2V}$$

41. Match List I with List II

	LIST I		LIST II
A.	Torque	I.	$[M^1L^1T^{-2}A^{-2}]$
B.	Magnetic field	II.	$[L^2A^1]$
C.	Magnetic moment	III.	$[M^1T^{-2}A^{-1}]$
D.	Permeability of free space	IV.	$[M^1L^2T^{-2}]$

Choose the **correct** answer from the options given below :

- (1) A-I, B-III, C-II, D-IV
 (2) A-IV, B-III, C-II, D-I
 (3) A-III, B-I, C-II, D-IV
 (4) A-IV, B-II, C-III, D-I

Ans. (2)

Sol. $[\vec{\tau}] = [\vec{r} \times \vec{F}] = [ML^2T^{-2}]$

$$[F] = [qVB]$$

$$\Rightarrow B = \left(\frac{F}{qV} \right) = \left[\frac{MLT^{-2}}{ATLT^{-1}} \right] = [MA^{-1}T^{-2}]$$

$$[M] = [I \times A] = [AL^2]$$

$$B = \frac{\mu_0 Idl \sin \theta}{4\pi r^2}$$

$$\Rightarrow [\mu] = \left[\frac{Br^2}{Idl} \right] = \left[\frac{MT^{-2}A^{-1} \times L^2}{AL} \right] = [MLT^{-2}A^{-2}]$$

42. Given below are two statements :

Statement I : In an LCR series circuit, current is maximum at resonance.

Statement II : Current in a purely resistive circuit can never be less than that in a series LCR circuit when connected to same voltage source.

In the light of the above statements, choose the **correct** from the options given below :

- (1) Statement I is true but Statement II is false
 (2) Statement I is false but Statement II is true
 (3) Both Statement I and Statement II are true
 (4) Both Statement I and Statement II are false

Ans. (3)

Sol. **Statement-I**

$$I_m = \frac{V_m}{\sqrt{R^2 + (X_L - X_C)^2}} \text{ at resonance } X_L = X_C$$

$$\text{Thus, } I_m = \frac{V_m}{R}$$

\therefore Impedence is minimum therefore I is maximum at resonance.

Statement-II

$$I = \left(\frac{V}{R} \right) \text{ in purely resistive circuit.}$$

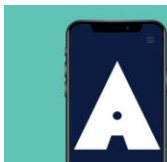

Download the new ALLEN app & enroll for Online Programs

CLICK HERE TO DOWNLOAD

43. The correct truth table for the following logic circuit is :

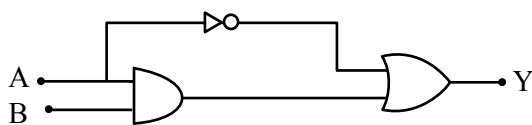

Options :

(1)

A	B	Y
0	0	0
0	1	1
1	0	0
1	1	1

(2)

A	B	Y
0	0	1
0	1	1
1	0	0
1	1	1

(3)

A	B	Y
0	0	1
0	1	1
1	0	0
1	1	0

(4)

A	B	Y
0	0	0
0	1	0
1	0	0
1	1	1

Ans. (2)

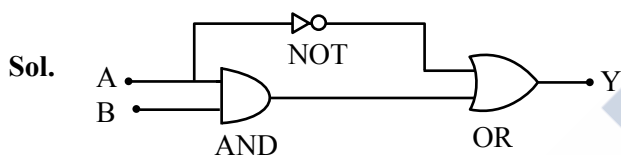

44. A sample contains mixture of helium and oxygen gas. The ratio of root mean square speed of helium and oxygen in the sample, is :

(1) $\frac{1}{32}$

(2) $\frac{2\sqrt{2}}{1}$

(3) $\frac{1}{4}$

(4) $\frac{1}{2\sqrt{2}}$

Ans. (2)

Sol.
$$V_{\text{rms}} = \sqrt{\frac{3RT}{M_w}}$$

$$\Rightarrow \frac{V_{\text{O}_2}}{V_{\text{He}}} = \sqrt{\frac{M_{w,\text{He}}}{M_{w,\text{O}_2}}}$$

$$= \sqrt{\frac{4}{32}} = \frac{1}{2\sqrt{2}}$$

$$\frac{V_{\text{He}}}{V_{\text{O}_2}} = \frac{2\sqrt{2}}{1}$$

45. A light string passing over a smooth light pulley connects two blocks of masses m_1 and m_2 (where $m_2 > m_1$). If the acceleration of the system is $\frac{g}{\sqrt{2}}$, then the ratio of the masses $\frac{m_1}{m_2}$ is :

(1) $\frac{\sqrt{2}-1}{\sqrt{2}+1}$

(2) $\frac{1+\sqrt{5}}{\sqrt{5}-1}$

(3) $\frac{1+\sqrt{5}}{\sqrt{2}-1}$

(4) $\frac{\sqrt{3}+1}{\sqrt{2}-1}$

Ans. (1)

Sol.
$$a = \left(\frac{M_2 - M_1}{M_1 + M_2} \right) g$$

$$\frac{g}{\sqrt{2}} = \left(\frac{M_2 - M_1}{M_1 + M_2} \right) g$$

$$(M_1 + M_2) = \sqrt{2}M_2 - \sqrt{2}M_1$$

$$\frac{M_1}{M_2} = \left(\frac{\sqrt{2}-1}{\sqrt{2}+1} \right)$$

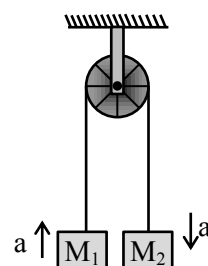

46. Four particles A, B, C, D of mass $\frac{m}{2}$, m , $2m$, $4m$, have same momentum, respectively. The particle with maximum kinetic energy is :

(1) D

(2) C

(3) A

(4) B

Ans. (3)

Sol.
$$KE = \frac{p^2}{2m}$$

Same momentum, so less mass means more KE.

So $\frac{m}{2}$ will have max. KE.

47. A train starting from rest first accelerates uniformly up to a speed of 80 km/h for time t , then it moves with a constant speed for time $3t$. The average speed of the train for this duration of journey will be (in km/h) :

(1) 80

(2) 70

(3) 30

(4) 40

Ans. (2)

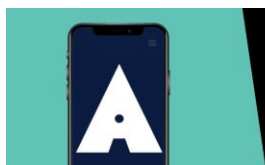

Download the new **ALLEN** app
& enroll for **Online Programs**

CLICK HERE TO
DOWNLOAD

Sol. Average speed = $\frac{\text{total distance}}{\text{time taken}}$

$$= \frac{\frac{80 \times t}{2} + 80 \times 3t}{4t} = 70 \text{ km/hr.}$$

48. An element $\Delta l = \Delta x \hat{i}$ is placed at the origin and carries a large current $I = 10\text{A}$. The magnetic field on the y -axis at a distance of 0.5 m from the elements Δx of 1 cm length is :

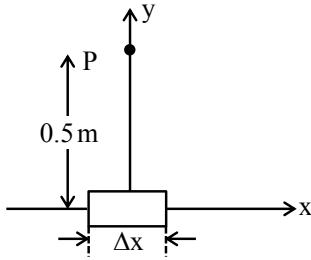

- (1) $4 \times 10^{-8}\text{ T}$ (2) $8 \times 10^{-8}\text{ T}$
 (3) $12 \times 10^{-8}\text{ T}$ (4) $10 \times 10^{-8}\text{ T}$

Ans. (1)

Sol.

$$\vec{dB} = \frac{\mu_0 I (d\vec{l} \times \vec{r})}{4\pi r^3} \text{ (Tesla)}$$

$$= \frac{10^{-7} \times 10 \times \left(\frac{1}{2} \times \frac{1}{100}\right) (+\hat{k})}{\left(\frac{1}{2}\right)^3} = 4 \times 10^{-8}\text{ T} (+\hat{k})$$

49. A small ball of mass m and density ρ is dropped in a viscous liquid of density ρ_0 . After sometime, the ball falls with constant velocity. The viscous force on the ball is :

- (1) $mg \left(\frac{\rho_0}{\rho} - 1\right)$ (2) $mg \left(1 + \frac{\rho}{\rho_0}\right)$
 (3) $mg(1 - \rho\rho_0)$ (4) $mg \left(1 - \frac{\rho_0}{\rho}\right)$

Ans. (4)

Sol. $mg - F_B - F_v = ma$
 $a = 0$ for constant velocity
 $mg - F_B = F_v$
 $F_v = mg - v \rho_0 g = mg - \frac{m}{\rho} \rho_0 g = mg \left(1 - \frac{\rho_0}{\rho}\right)$

50. In photoelectric experiment energy of 2.48 eV irradiates a photo sensitive material. The stopping potential was measured to be 0.5 V . Work function of the photo sensitive material is :
 (1) 0.5 eV (2) 1.68 eV
 (3) 2.48 eV (4) 1.98 eV

Ans. (4)

Sol. $eV_s = hv - \phi$
 $0.5\text{ V} = 2.48 - \phi$
 work function (ϕ) = $2.48\text{ V} - 0.5\text{ V} = 1.98\text{ V}$

SECTION-B

51. If the radius of earth is reduced to three-fourth of its present value without change in its mass then value of duration of the day of earth will be _____ hours 30 minutes.

Ans. (13)

Sol. By conservation of angular momentum
 $I_1 \omega_1 = I_2 \omega_2$
 $\left(\frac{2}{5} MR^2\right) \frac{2\pi}{T_1} = \frac{2}{5} M \left(\frac{3}{4} R\right)^2 \frac{2\pi}{T_2}$
 $\frac{1}{T_1} = \frac{9}{16 T_2}$
 $\frac{1}{T_2} = \frac{9}{16} \times T_1 = \frac{9}{16} \times 24\text{ hr} = \frac{27}{2}\text{ hr} = 13\text{ hr } 30\text{ mins.}$

52. Three infinitely long charged thin sheets are placed as shown in figure. The magnitude of electric field at the point P is $\frac{x\sigma}{\epsilon_0}$. The value of x is _____ (all quantities are measured in SI units).

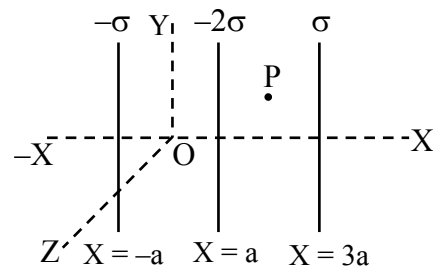

Ans. (2)

Download the new ALLEN app & enroll for Online Programs

[CLICK HERE TO DOWNLOAD](#)

Sol.

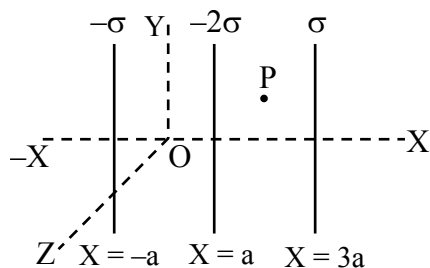

$$\vec{E}_p = \left(\frac{\sigma}{2\epsilon_0} + \frac{2\sigma}{2\epsilon_0} + \frac{\sigma}{2\epsilon_0} \right) (-\hat{i})$$

$$= -\frac{2\sigma}{\epsilon_0} \hat{i}$$

53. A big drop is formed by coalescing 1000 small droplets of water. The ratio of surface energy of 1000 droplets to that of energy of big drop is $\frac{10}{x}$.

The value of x is _____.

Ans. (1)

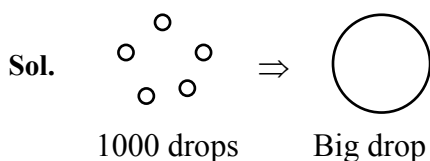

$$1000 \frac{4}{3} \pi r^3 = \frac{4}{3} \pi R^3$$

$$10r = R$$

$$R = 10r$$

$$\frac{\text{S.E. of 1000 drops}}{\text{S.E. of Big drop}} = \frac{1000(4\pi r^2)T}{4\pi R^2 T}$$

$$= \frac{1000 \times r^2}{(10r)^2} = 10 = \frac{10}{x}$$

$$\therefore x = 1$$

54. When a dc voltage of 100V is applied to an inductor, a dc current of 5A flows through it. When an ac voltage of 200V peak value is connected to inductor, its inductive reactance is found to be $20\sqrt{3} \Omega$. The power dissipated in the circuit is _____ W.

Ans. (250)

Sol. For DC voltage

$$R = \frac{V}{I} = \frac{100}{5} = 20 \Omega$$

for AC voltage

$$X_L = 20\sqrt{3} \Omega$$

$$R = 20 \Omega$$

$$Z = \sqrt{X_L^2 + R^2} = \sqrt{3 \times 400 + 400} = 40 \Omega$$

$$\text{Power} = i_{\text{rms}}^2 R$$

$$= \left(\frac{V_{\text{rms}}}{Z} \right)^2 \times R = \left(\frac{200}{40} \right)^2 \times 20 = 250 \text{ W}$$

55. The refractive index of prism is $\mu = \sqrt{3}$ and the ratio of the angle of minimum deviation to the angle of prism is one. The value of angle of prism is _____ °.

Ans. (60)

Sol. For δ_{\min}

$$i = e$$

$$r_1 = r_2 = \frac{A}{2}$$

$$\frac{\delta_{\min}}{A} = 1$$

$$\frac{2i - A}{A} = 1$$

$$2i = 2A$$

$$i = A$$

Snell's law

$$1 \times \sin i = \mu \sin r$$

$$\sin i = \mu \sin \left(\frac{A}{2} \right)$$

$$\sin A = \mu \sin \left(\frac{A}{2} \right)$$

$$2 \sin \frac{A}{2} \cos \frac{A}{2} = \sqrt{3} \sin \left(\frac{A}{2} \right)$$

$$\cos \left(\frac{A}{2} \right) = \frac{\sqrt{3}}{2}$$

$$\therefore \frac{A}{2} = 30^\circ$$

$$\therefore A = 60^\circ$$

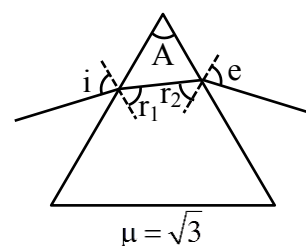

56. A wire of resistance R and radius r is stretched till its radius became $r/2$. If new resistance of the stretched wire is xR , then value of x is _____.

Ans. (16)

Sol. We know $R = \frac{\rho l}{A}$, $R \propto \frac{l}{r^2}$

As we stretch the wire, its length will increase but its radius will decrease keeping the volume constant

$$V_i = V_f$$

$$\pi r^2 l = \pi \frac{r_f^2}{4} l_f$$

$$l_f = 4l$$

$$\frac{R_{\text{new}}}{R_{\text{old}}} = \left(\frac{4l}{\frac{r^2}{4}} \right) \frac{r^2}{l} = 16$$

$$R_{\text{new}} = 16R$$

$$\therefore x = 16$$

57. Radius of a certain orbit of hydrogen atom is 8.48 \AA . If energy of electron in this orbit is E/x , then $x =$ _____.

(Given $a_0 = 0.529 \text{ \AA}$, $E =$ energy of electron in ground state)

Ans. (16)

Sol. We know

$$r = 0.529 \frac{n^2}{Z} \Rightarrow 8.48 = 0.529 \frac{n^2}{1}$$

$$n^2 = 16 \Rightarrow n = 4$$

We know

$$E \propto \frac{1}{n^2}$$

$$E_{n^{\text{th}}} = \frac{E}{16}$$

$$x = 16$$

58. A circular coil having 200 turns, $2.5 \times 10^{-4} \text{ m}^2$ area and carrying $100 \mu\text{A}$ current is placed in a uniform magnetic field of 1 T . Initially the magnetic dipole moment (\vec{M}) was directed along \vec{B} . Amount of work, required to rotate the coil through 90° from its initial orientation such that \vec{M} becomes perpendicular to \vec{B} , is _____ μJ .

Ans. (5)

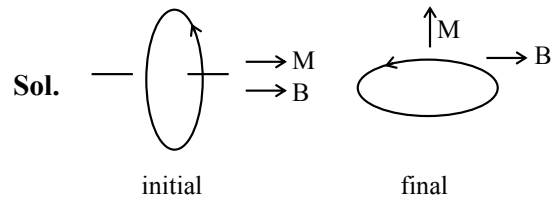

Sol.

We know

$$W_{\text{ext}} = \Delta U + \Delta \text{KE} \quad (\text{P.E.} = -\vec{M} \cdot \vec{B})$$

$$= -\vec{M} \cdot \vec{B}_f + \vec{M} \cdot \vec{B}_i + 0$$

$$= -MB \cos 90 + MB \cos 0$$

$$= MB$$

$$= NIAB$$

$$= 200 \times 100 \times 10^{-6} \times \frac{5}{2} \times 10^{-4} \times 1 = 5 \mu\text{J}$$

59. A particle is doing simple harmonic motion of amplitude 0.06 m and time period 3.14 s . The maximum velocity of the particle is _____ cm/s .

Ans. (12)

Sol. We know

$$v_{\text{max}} = \omega A \quad \text{at mean position}$$

$$= \frac{2\pi}{T} A = \frac{2\pi}{\pi} \times 0.06 = 0.12 \text{ m/sec}$$

$$v_{\text{max}} = 12 \text{ cm/sec}$$

60. For three vectors $\vec{A} = (-x\hat{i} - 6\hat{j} - 2\hat{k})$, $\vec{B} = (-\hat{i} + 4\hat{j} + 3\hat{k})$ and $\vec{C} = (-8\hat{i} - \hat{j} + 3\hat{k})$, if $\vec{A} \cdot (\vec{B} \times \vec{C}) = 0$, then value of x is _____.

Ans. (4)

$$\text{Sol. } \vec{B} \times \vec{C} = \begin{vmatrix} \hat{i} & \hat{j} & \hat{k} \\ -1 & 4 & 3 \\ -8 & -1 & 3 \end{vmatrix} = 15\hat{i} - 21\hat{j} + 33\hat{k}$$

$$\vec{A} \cdot (\vec{B} \times \vec{C}) = (-x\hat{i} - 6\hat{j} - 2\hat{k}) \cdot (15\hat{i} - 21\hat{j} + 33\hat{k})$$

$$0 = -15x + 126 - 66$$

$$15x = 60$$

$$x = 4$$