

FINAL JEE-MAIN EXAMINATION – APRIL, 2024

(Held On Tuesday 09th April, 2024)

TIME : 9 : 00 AM to 12 : 00 NOON

PHYSICS

TEST PAPER WITH SOLUTION

SECTION-A

31. A proton, an electron and an alpha particle have the same energies. Their de-Broglie wavelengths will be compared as:

- (1) $\lambda_e > \lambda_\alpha > \lambda_p$ (2) $\lambda_\alpha < \lambda_p < \lambda_e$
 (3) $\lambda_p < \lambda_e < \lambda_\alpha$ (4) $\lambda_p > \lambda_e > \lambda_\alpha$

Ans. (2)

Sol. $\lambda_{DB} = \frac{h}{p} = \frac{h}{\sqrt{2mk}}$
 $\Rightarrow \lambda_{DB} \propto \frac{1}{\sqrt{m}}$
 $\Rightarrow \lambda_a < \lambda_p < \lambda_e$

32. A particle moving in a straight line covers half the distance with speed 6 m/s. The other half is covered in two equal time intervals with speeds 9 m/s and 15 m/s respectively. The average speed of the particle during the motion is :

- (1) 8.8 m/s (2) 10 m/s
 (3) 9.2 m/s (4) 8 m/s

Ans. (4)

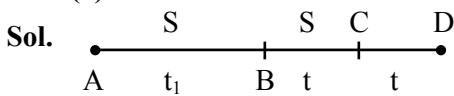

$BD \Rightarrow S = 9t + 15t = 24t$
 $AB \Rightarrow S = 6t_1 = 24t \Rightarrow t_1 = 4t$
 $\langle \text{speed} \rangle = \frac{\text{dist.}}{\text{time}} = \frac{48t}{2t + t_1}$
 $= \frac{48t}{2t + 4t} \Rightarrow \frac{48t}{6t} \Rightarrow 8 \text{ m/s}$

33. A plane EM wave is propagating along x direction. It has a wavelength of 4 mm. If electric field is in y direction with the maximum magnitude of 60 Vm^{-1} , the equation for magnetic field is:

- (1) $B_z = 60 \sin \left[\frac{\pi}{2} (x - 3 \times 10^8 t) \right] \hat{k} \text{T}$
 (2) $B_z = 2 \times 10^{-7} \sin \left[\frac{\pi}{2} \times 10^3 (x - 3 \times 10^8 t) \right] \hat{k} \text{T}$
 (3) $B_x = 60 \sin \left[\frac{\pi}{2} (x - 3 \times 10^8 t) \right] \hat{i} \text{T}$
 (4) $B_z = 2 \times 10^{-7} \sin \left[\frac{\pi}{2} (x - 3 \times 10^8 t) \right] \hat{k} \text{T}$

Ans. (2)

Sol. $E = BC \Rightarrow 60 = B \times 3 \times 10^8$
 $\Rightarrow B = 2 \times 10^{-7}$

Also $C = f\lambda$
 $\Rightarrow 3 \times 10^8 = f \times 4 \times 10^{-3}$
 $\Rightarrow f = \frac{3}{4} \times 10^{11}$
 $\Rightarrow \omega = 2\pi f = \frac{3}{4} \times 2\pi \times 10^{11}$

$\Rightarrow \omega = \frac{\pi}{2} \times 10^3 \text{ C}$
 \Rightarrow Electric field \Rightarrow y direction
 Propagation \Rightarrow x direction
 Magnetic field \Rightarrow z-direction

34. Given below are two statements:

Statement (I): When an object is placed at the centre of curvature of a concave lens, image is formed at the centre of curvature of the lens on the other side.

Statement (II): Concave lens always forms a virtual and erect image.

In the light of the above statements, choose the correct answer from the options given below:

- (1) **Statement I** is false but **Statement II** is true.
 (2) Both **Statement I** and **Statement II** are false.
 (3) **Statement I** is true but **Statement II** is false.
 (4) Both **Statement I** and **Statement II** are true.

NTA Ans. (1)

Allen Ans. (2)

Sol. $\frac{1}{v} - \frac{1}{u} = \frac{1}{f}$
 $\frac{1}{v} - \frac{1}{-2f} = \frac{1}{-f}$
 $\Rightarrow \frac{1}{v} = \frac{-1}{2f} \Rightarrow v = -2f$
 $\frac{1}{v} = \frac{1}{u} + \frac{1}{f} \Rightarrow$ Virtual image of Real object.

In statement II, it is not mentioned that object is real or virtual hence Statement II is false.

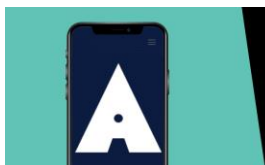

Download the new **ALLEN** app
& enroll for **Online Programs**

CLICK HERE TO
DOWNLOAD

35. A light emitting diode (LED) is fabricated using GaAs semiconducting material whose band gap is 1.42 eV. The wavelength of light emitted from the LED is:

- (1) 650 nm (2) 1243 nm
(3) 875 nm (4) 1400 nm

Ans. (3)

Sol. $\lambda = \frac{1240}{1.42} = 875 \text{ nm (Approx)}$

36. A sphere of relative density σ and diameter D has concentric cavity of diameter d . The ratio of $\frac{D}{d}$, if it just floats on water in a tank is:

- (1) $\left(\frac{\sigma}{\sigma-1}\right)^{\frac{1}{3}}$ (2) $\left(\frac{\sigma+1}{\sigma-1}\right)^{\frac{1}{3}}$
(3) $\left(\frac{\sigma-1}{\sigma}\right)^{\frac{1}{3}}$ (4) $\left(\frac{\sigma-2}{\sigma+2}\right)^{\frac{1}{3}}$

Ans. (1)

Sol. weight (w) = $\frac{4}{3}\pi\left(\frac{D^3-d^3}{8}\right)\sigma g$

Buoyant force (F_b) = $1 \times \frac{4}{3}\pi\left(\frac{D^3}{8}\right) \cdot g$

For Just Float $\Rightarrow w = F_b$

$\Rightarrow (D^3 - d^3)\sigma = D^3$

$\Rightarrow 1 - \frac{d^3}{D^3} = \frac{1}{\sigma}$

$\Rightarrow 1 - \frac{1}{\sigma} = \left(\frac{d}{D}\right)^3$

$\Rightarrow \left(\frac{\sigma}{\sigma-1}\right)^{\frac{1}{3}} = \left(\frac{D}{d}\right)$

37. A capacitor is made of a flat plate of area A and a second plate having a stair-like structure as shown in figure. If the area of each stair is $\frac{A}{3}$ and the height is d , the capacitance of the arrangement is:

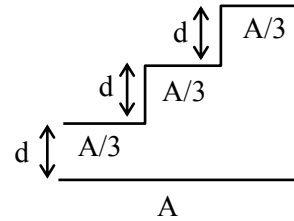

- (1) $\frac{11\epsilon_0 A}{18d}$ (2) $\frac{13\epsilon_0 A}{17d}$
(3) $\frac{11\epsilon_0 A}{20d}$ (4) $\frac{18\epsilon_0 A}{11d}$

Ans. (1)

Sol. All capacitor are in parallel combination. Also effective area is common area only

$\Rightarrow C_{eq} = C_1 + C_2 + C_3$

$\Rightarrow C_{eq} = \frac{A\epsilon_0}{3d} + \frac{A\epsilon_0}{3(2d)} + \frac{A\epsilon_0}{3(3d)}$

$\Rightarrow C_{eq} = \frac{A\epsilon_0}{3} \left(\frac{11}{6d}\right)$

$\Rightarrow C_{eq} = \frac{11A\epsilon_0}{18d}$

38. A light unstretchable string passing over a smooth light pulley connects two blocks of masses m_1 and m_2 . If the acceleration of the system is $\frac{g}{8}$, then the

ratio of the masses $\frac{m_2}{m_1}$ is:

- (1) 9 : 7 (2) 4 : 3
(3) 5 : 3 (4) 8 : 1

Ans. (1)

Sol. $a_{sys} = \left(\frac{m_2 - m_1}{m_1 + m_2}\right)g = \frac{g}{8}$

$\Rightarrow \frac{m_2}{m_1} = \frac{9}{7}$

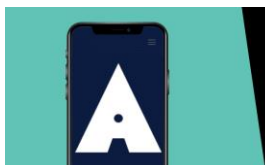

Download the new **ALLEN** app
& enroll for **Online Programs**

CLICK HERE TO
DOWNLOAD

39. The dimensional formula of latent heat is:

- (1) $[M^0LT^{-2}]$ (2) $[MLT^{-2}]$
 (3) $[M^0L^2T^{-2}]$ (4) $[ML^2T^{-2}]$

Ans. (3)

Sol. Latent heat is specific heat

$$\Rightarrow \frac{ML^2T^{-2}}{M} = M^0L^2T^{-2}$$

40. The volume of an ideal gas ($\gamma = 1.5$) is changed adiabatically from 5 litres to 4 litres. The ratio of initial pressure to final pressure is:

- (1) $\frac{4}{5}$ (2) $\frac{16}{25}$
 (3) $\frac{8}{5\sqrt{5}}$ (4) $\frac{2}{\sqrt{5}}$

Ans. (3)

Sol. For Adiabatic process

$$P_i V_i^\gamma = P_f V_f^\gamma$$

$$P_i (5)^{1.5} = P_f (4)^{1.5}$$

$$\frac{P_i}{P_f} = \left(\frac{4}{5}\right)^{\frac{3}{2}} = \frac{4}{5} \cdot \left(\frac{4}{5}\right)^{\frac{1}{2}} \Rightarrow \frac{8}{5\sqrt{5}}$$

41. The energy equivalent of 1g of substance is:

- (1) 11.2×10^{24} MeV (2) 5.6×10^{12} MeV
 (3) 5.6 eV (4) 5.6×10^{26} MeV

Ans. (4)

Sol. $E = mc^2$

$$\Rightarrow E = (1 \times 10^{-3}) \times (3 \times 10^8)^2 \text{ J}$$

$$\Rightarrow E = (10^{-3}) (9 \times 10^{16}) (6.241 \times 10^{18}) \text{ eV}$$

$$E = 56.169 \times 10^{31} \text{ eV}$$

$$E \approx 5.6 \times 10^{26} \text{ MeV}$$

42. An astronaut takes a ball of mass m from earth to space. He throws the ball into a circular orbit about earth at an altitude of 318.5 km. From earth's surface to the orbit, the change in total mechanical energy of the ball is $x \frac{GM_e m}{21R_e}$. The value of x is

(take $R_e = 6370$ km):

- (1) 11 (2) 9
 (3) 12 (4) 10

Ans. (1)

Sol. $h = 318.5 \approx \left(\frac{R_e}{20}\right)$

$$T \cdot E_i = \frac{-GM_e m}{R_e}$$

$$T \cdot E_f = \frac{-GM_e m}{2(R_e + h)} = \frac{-GM_e m}{2\left(R_e + \frac{R_e}{20}\right)}$$

$$\Rightarrow T \cdot E_f = \frac{-10GM_e m}{21R_e}$$

Change in total mechanical energy

$$= TE_f - TE_i$$

$$= \frac{GM_e m}{R_e} \left[1 - \frac{10}{21}\right] = \frac{11GM_e m}{21R_e}$$

43. Given below are two statements:

Statement (I) : When currents vary with time, Newton's third law is valid only if momentum carried by the electromagnetic field is taken into account.

Statement (II) : Ampere's circuital law does not depend on Biot-Savart's law.

In the light of the above statements, choose the **correct** answer from the options given below:

- (1) Both **Statement I** and **Statement II** are false.
 (2) **Statement I** is true but **Statement II** is false.
 (3) **Statement I** is false but **Statement II** is true.
 (4) Both **Statement I** and **Statement II** are true.

Ans. (2)

Sol. Conceptual.

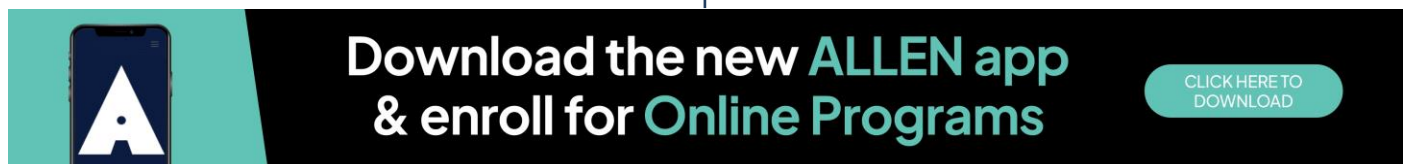

Download the new ALLEN app & enroll for Online Programs

CLICK HERE TO DOWNLOAD

44. A particle of mass m moves on a straight line with its velocity increasing with distance according to the equation $v = \alpha\sqrt{x}$, where α is a constant. The total work done by all the forces applied on the particle during its displacement from $x = 0$ to $x = d$, will be:

- (1) $\frac{m}{2\alpha^2 d}$ (2) $\frac{md}{2\alpha^2}$
 (3) $\frac{m\alpha^2 d}{2}$ (4) $2m\alpha^2 d$

Ans. (3)

Sol. $v = \alpha\sqrt{x}$
 at $x = 0$: $v = 0$
 & at $x = d$; $v = \alpha\sqrt{d}$
 $W.D = K_f - K_i$
 $W.D = \frac{1}{2}m(\alpha\sqrt{d})^2 - \frac{1}{2}m(0)^2$
 $\Rightarrow W.D = \frac{m\alpha^2 d}{2}$

45. A galvanometer has a coil of resistance 200Ω with a full scale deflection at $20 \mu A$. The value of resistance to be added to use it as an ammeter of range $(0-20) mA$ is:

- (1) 0.40Ω (2) 0.20Ω
 (3) 0.50Ω (4) 0.10Ω

Ans. (2)

Sol. $G = 200 \Omega$
 $i_g = 20 \mu A$
 $i = i_g \left(\frac{G}{S} + 1 \right)$
 $\Rightarrow 20 \times 10^{-3} = 20 \times 10^{-6} \left(\frac{200}{S} + 1 \right)$
 $\Rightarrow \frac{200}{S} = 999$
 $\Rightarrow S \approx 0.2 \Omega$

46. A heavy iron bar, of weight W is having its one end on the ground and the other on the shoulder of a person. The bar makes an angle θ with the horizontal. The weight experienced by the person is:

- (1) $\frac{W}{2}$ (2) W
 (3) $W \cos \theta$ (4) $W \sin \theta$

Ans. (1)

Sol.

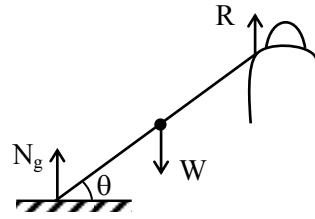

$R =$ net reaction force by shoulder

Balancing torque about pt of contact on ground:

$$W \left(\frac{L}{2} \cos \theta \right) = R (L \cos \theta)$$

$$\Rightarrow R = \frac{W}{2}$$

47. One main scale division of a vernier caliper is equal to m units. If n^{th} division of main scale coincides with $(n + 1)^{\text{th}}$ division of vernier scale, the least count of the vernier caliper is:

- (1) $\frac{n}{(n+1)}$ (2) $\frac{m}{(n+1)}$
 (3) $\frac{1}{(n+1)}$ (4) $\frac{m}{n(n+1)}$

Ans. (2)

Sol. $n \text{ MSD} = (n + 1) \text{ VSD}$
 $\Rightarrow 1 \text{ VSD} = \frac{n}{n + 1} \text{ MSD}$
 $L.C = 1 \text{ MSD} - 1 \text{ VSD}$
 $L.C = m - m \left(\frac{n}{n + 1} \right)$
 $L.C = m \left(\frac{n + 1 - n}{n + 1} \right)$
 $\Rightarrow L.C = \left(\frac{m}{n + 1} \right)$

48. A bulb and a capacitor are connected in series across an ac supply. A dielectric is then placed between the plates of the capacitor. The glow of the bulb:

- (1) increases (2) remains same
 (3) becomes zero (4) decreases

Ans. (1)

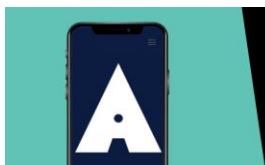

Download the new **ALLEN** app
 & enroll for **Online Programs**

CLICK HERE TO
 DOWNLOAD

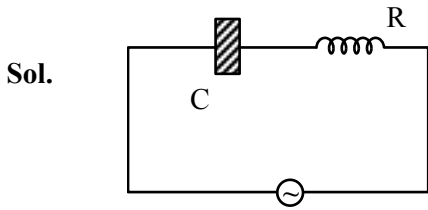

$$Z = \sqrt{R^2 + X_C^2} \text{ \& \ } X_C = \frac{1}{\omega C}$$

due to dielectric

$$C \uparrow \Rightarrow X_C \downarrow \Rightarrow Z \downarrow$$

So, current increases & thus bulb will glow more brighter.

49. The equivalent resistance between A and B is:

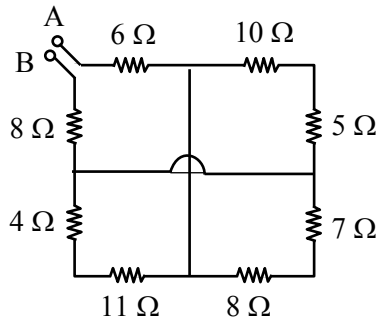

- (1) 18 Ω (2) 25 Ω
 (3) 27 Ω (4) 19 Ω

Ans. (4)

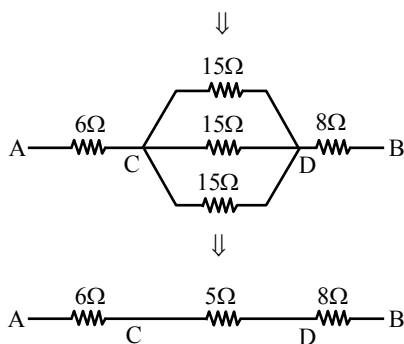
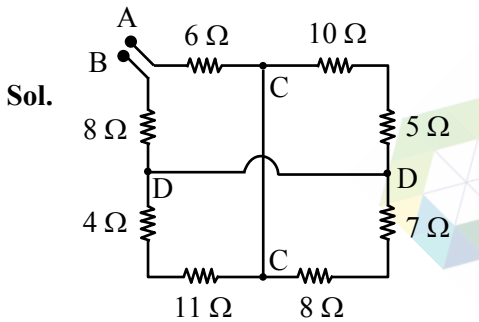

$$\Rightarrow R_{eq} = 6\Omega + 5\Omega + 8\Omega = 19\Omega$$

50. A sample of 1 mole gas at temperature T is adiabatically expanded to double its volume. If adiabatic constant for the gas is $\gamma = \frac{3}{2}$, then the work done by the gas in the process is:

- (1) $RT[2 - \sqrt{2}]$ (2) $\frac{R}{T}[2 - \sqrt{2}]$
 (3) $RT[2 + \sqrt{2}]$ (4) $\frac{T}{R}[2 + \sqrt{2}]$

Ans. (1)

Sol. $TV^{\gamma-1} = \text{constant}$

$$\Rightarrow T(V)^{\frac{3}{2}-1} = T_f(2V)^{\frac{3}{2}-1}$$

$$\Rightarrow TV^{\frac{1}{2}} = T_f(2)^{\frac{1}{2}}(V)^{\frac{1}{2}}$$

$$\Rightarrow T_f = \left(\frac{T}{\sqrt{2}}\right)$$

$$\text{Now, W.D.} = \frac{nR\Delta T}{1-\gamma} = \frac{1 \cdot R \left[\frac{T}{\sqrt{2}} - T \right]}{1 - \frac{3}{2}}$$

$$\Rightarrow \text{W.D.} = 2RT \left[1 - \frac{1}{\sqrt{2}} \right]$$

$$\Rightarrow \text{W.D.} = RT[2 - \sqrt{2}]$$

SECTION-B

51. If \vec{a} and \vec{b} makes an angle $\cos^{-1}\left(\frac{5}{9}\right)$ with each other, then $|\vec{a} + \vec{b}| = \sqrt{2} |\vec{a} - \vec{b}|$ for $|\vec{a}| = n |\vec{b}|$. The integer value of n is _____.

Ans. (3)

Sol. $\cos\theta = \frac{5}{9}$

$$\frac{\vec{a} \cdot \vec{b}}{ab} = \frac{5}{9} \dots\dots(1)$$

$$|\vec{a} + \vec{b}| = \sqrt{2} |\vec{a} - \vec{b}|$$

$$a^2 + b^2 + 2\vec{a} \cdot \vec{b} = 2a^2 + 2b^2 - 4\vec{a} \cdot \vec{b}$$

$$6\vec{a} \cdot \vec{b} = a^2 + b^2$$

$$6 \times \frac{5}{9} ab = a^2 + b^2$$

$$\frac{10}{3} ab = a^2 + b^2 \quad \& \quad a = nb$$

$$\frac{10}{3} nb^2 = n^2 b^2 + b^2$$

$$3n^2 - 10n + 3 = 0$$

$$n = \frac{1}{3} \quad \text{and} \quad n = 3$$

integer value $n = 3$

52. At the centre of a half ring of radius $R = 10$ cm and linear charge density $4n$ C m^{-1} , the potential is $x \pi$ V. The value of x is _____.

Ans. (36)

Sol. Potential at centre of half ring

$$V = \frac{KQ}{R}$$

$$V = \frac{K\lambda\pi R}{R}$$

$$V = K\lambda\pi \Rightarrow V = 9 \times 10^9 \times 4 \times 10^{-9}\pi$$

$$V = 36\pi$$

53. A star has 100% helium composition. It starts to convert three ${}^4\text{He}$ into one ${}^{12}\text{C}$ via triple alpha process as ${}^4\text{He} + {}^4\text{He} + {}^4\text{He} \rightarrow {}^{12}\text{C} + Q$. The mass of the star is 2.0×10^{32} kg and it generates energy at the rate of 5.808×10^{30} W. The rate of converting these ${}^4\text{He}$ to ${}^{12}\text{C}$ is $n \times 10^{42} \text{ s}^{-1}$, where n is _____.

[Take, mass of ${}^4\text{He} = 4.0026$ u, mass of ${}^{12}\text{C} = 12$ u]

NTA Ans. (5)

Allen Ans. (15)

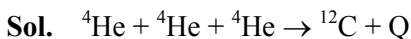

$$\text{power generated} = \frac{N}{t} Q$$

where, $N \rightarrow$ No. of reaction/sec.

$$Q = (3m_{\text{He}} - m_{\text{C}})C^2$$

$$Q = (3 \times 4.0026 - 12) (3 \times 10^8)^2$$

$$Q = 7.266 \text{ MeV}$$

$$\frac{N}{t} = \frac{\text{power}}{Q} = \frac{5.808 \times 10^{30}}{7.266 \times 10^6 \times 1.6 \times 10^{-19}}$$

$$\frac{N}{t} = 5 \times 10^{42}$$

rate of conversion of ${}^4\text{He}$ into ${}^{12}\text{C} = 15 \times 10^{42}$

Hence, $n = 15$

54. In a Young's double slit experiment, the intensity at a point is $\left(\frac{1}{4}\right)^{\text{th}}$ of the maximum intensity, the minimum distance of the point from the central maximum is _____ μm .
(Given : $\lambda = 600$ nm, $d = 1.0$ mm, $D = 1.0$ m)

Ans. (200)

Sol. $I = I_0 \cos^2\left(\frac{\Delta\phi}{2}\right)$

$$\frac{I_0}{4} = \cos^2\left(\frac{\Delta\phi}{2}\right)$$

$$\Delta\phi = \frac{2\pi}{3}$$

$$\frac{2\pi}{\lambda} \left(\frac{yd}{D}\right) = \frac{2\pi}{3}$$

$$y = \frac{\lambda D}{3d} = \frac{600 \times 10^{-9} \times 1}{3 \times 10^{-3}} = 2 \times 10^{-4} \text{ m}$$

55. A string is wrapped around the rim of a wheel of moment of inertia 0.40 kgm^2 and radius 10 cm. The wheel is free to rotate about its axis. Initially the wheel is at rest. The string is now pulled by a force of 40 N. The angular velocity of the wheel after 10 s is x rad/s, where x is _____.

Ans. (100)

Sol. $\tau = FR = I\alpha \Rightarrow 40 \times 0.1 = 0.4\alpha$

$$\alpha = 10 \text{ rad/s}^2$$

$$W_f = 10 \times 10 = 100 \text{ rad/s}$$

56. A square loop of edge length 2 m carrying current of 2 A is placed with its edges parallel to the x - y axis. A magnetic field is passing through the x - y plane and expressed as $\vec{B} = B_0(1+4x)\hat{k}$, where $B_0 = 5$ T. The net magnetic force experienced by the loop is _____ N.



Download the new **ALLEN** app
& enroll for **Online Programs**

CLICK HERE TO
DOWNLOAD

Ans. (160)

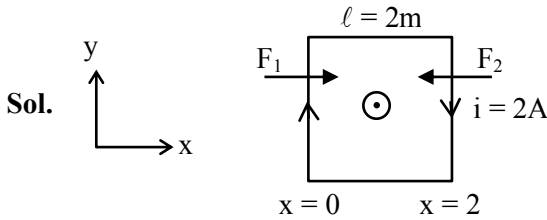

$$B(x=0) = B_0, \quad B(x=2) = 9B_0$$

Also, $F = i\ell B$

$$\Rightarrow F_1 = i\ell B_0 \quad \& \quad F_2 = 9i\ell B_0$$

$$F = F_2 - F_1 = 8i\ell B_0 = 8 \times 2 \times 2 \times 5$$

$$F = 160 \text{ N}$$

57. Two persons pull a wire towards themselves. Each person exerts a force of 200 N on the wire. Young's modulus of the material of wire is $1 \times 10^{11} \text{ N m}^{-2}$. Original length of the wire is 2 m and the area of cross section is 2 cm^2 . The wire will extend in length by _____ μm .

Ans. (20)



$$\frac{F}{A} = Y \frac{\Delta \ell}{\ell} \Rightarrow \Delta \ell = \frac{F\ell}{AY}$$

$$\Delta \ell = \frac{200 \times 2}{2 \times 10^{-4} \times 10^{11}} = 2 \times 10^{-5} = 20 \mu\text{m}$$

58. When a coil is connected across a 20 V dc supply, it draws a current of 5 A. When it is connected across 20 V, 50 Hz ac supply, it draws a current of 4 A. The self inductance of the coil is _____ mH. (Take $\pi = 3$)

Ans. (10)

Sol. Case-I:

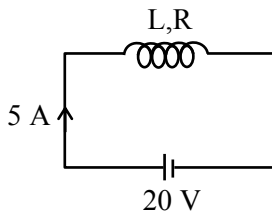

$$i = \frac{20}{R} \Rightarrow R = 4\Omega$$

Case-II:

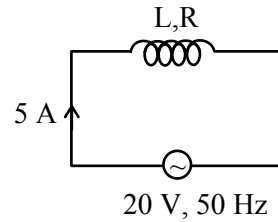

$$i = \frac{20}{Z}$$

$$4 = \frac{20}{\sqrt{R^2 + X_L^2}} \Rightarrow \sqrt{R^2 + X_L^2} = 5$$

$$R^2 + X_L^2 = 25 \Rightarrow X_L = 3 \Omega$$

$$L = \frac{3}{2\pi f} = \frac{1}{2 \times 50} = \frac{1000}{100} \text{ mH}$$

$$L = 10 \text{ mH}$$

59. The position, velocity and acceleration of a particle executing simple harmonic motion are found to have magnitudes of 4 m, 2 ms^{-1} and 16 ms^{-2} at a certain instant. The amplitude of the motion is \sqrt{x} m where x is _____.

Ans. (17)

Sol. $x = 4 \text{ m}$, $V = 2 \text{ m/s}$, $a = 16 \text{ m/s}^2$

$$|a| = \omega^2 x$$

$$\Rightarrow 16 = \omega^2(4)$$

$$\omega = 2 \text{ rad/s}$$

$$v = \omega \sqrt{A^2 - x^2}$$

$$A = \sqrt{\frac{v^2}{\omega^2} + x^2} \Rightarrow A = \sqrt{\frac{4}{4} + 16}$$

$$A = \sqrt{17} \text{ m}$$

60. The current flowing through the 1Ω resistor is $\frac{n}{10}$

A. The value of n is _____.

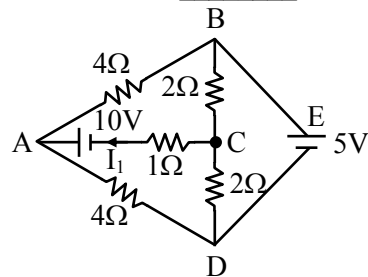

Ans. (25)

Sol.

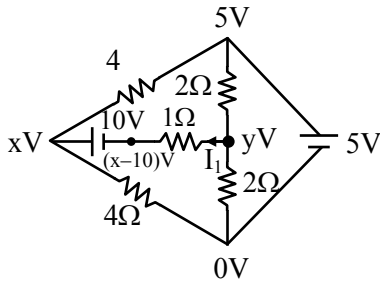

$$\frac{y-5}{2} + \frac{y-0}{2} + \frac{y-x+10}{1} = 0$$

$$y-5+y+2y-2x+20=0$$

$$4y-2x+15=0 \quad \dots(i)$$

$$\frac{x-5}{4} + \frac{x-0}{4} + \frac{x-10-y}{1} = 0$$

$$x-5+x+4x-40-4y=0$$

$$6x-4y-45=0 \quad \dots(ii)$$

$$-2x+4y+15=0 \quad \dots(iii)$$

$$4x-30=0$$

$$x = \frac{15}{2} \quad \& \quad 4y - 15 + 15 = 0$$

$$y = 0$$

$$i = \frac{y-x+10}{1}$$

$$i = \frac{0 - 7.5 + 10}{1}$$

$$i = 2.5A = \frac{n}{10} A$$

$$n = 25$$



ALLEN
OVERSEAS



Download the new **ALLEN** app
& enroll for **Online Programs**

CLICK HERE TO
DOWNLOAD